

GEA Procomac Fillstar FX

Volumetric electronic aseptic filler for still products



Fillstar FX series is the GEA Procomac range of aseptic volumetric electronic fillers with magnetic flow meters for any still product, including high acid, low acid, clear, with pulps, fibres, pieces and viscous drinks.

The product is pushed by an overpressure of sterile air or sterile nitrogen gas, through a linear product path.

The filling process is made without contact between the filling nozzle and the bottle to avoid cross contamination.

The flow meter determines the quantity of liquid according to the container and closes a membrane valve when the preset quantity is reached. There is no other moving component in contact with the product.

Furthermore, a dual speed design (slow speed mode is used at beginning and end of filling cycle) allows to avoid foaming even with critical products.

Key feature of FX fillers is the internal sterilization by means of steam. Changeover is performed without breaking of sterility for any container with the same neck finish, due to complete bottle "neck handling" system.

CIP cups insertion and extraction for closed-loop CIP and SIP are completely automatic.

Product change is totally automatic and ensures the complete change from different products in less than 30 min with minimal product scraps.

Features

- Volumetric electronic filling head with magnetic flow meter
- On board aseptic tank
- Excellent features for aseptic filling of still liquid
- No contact between filling nozzle and the bottle neck
- Automatic CIP cups insertion and extraction for closed-loop CIP (international patent)
- User-friendly touchscreen control panel

Advantages

- Advanced product and container flexibility:
 - clear products or products containing pulps and fibres filling capability;
 - complete neck handling system: fast bottle changeover;
 - self-adapting grippers to treat bottles with different neck diameters available as an option.
- Optimal hygiene
- Fully automatic CIP and SIP cycles

GEA Procomac range of FX volumetric electronic fillers includes:

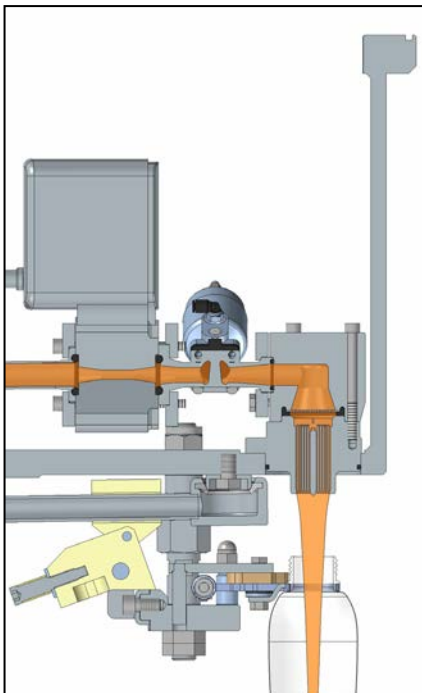

FX filling valve for still clear products

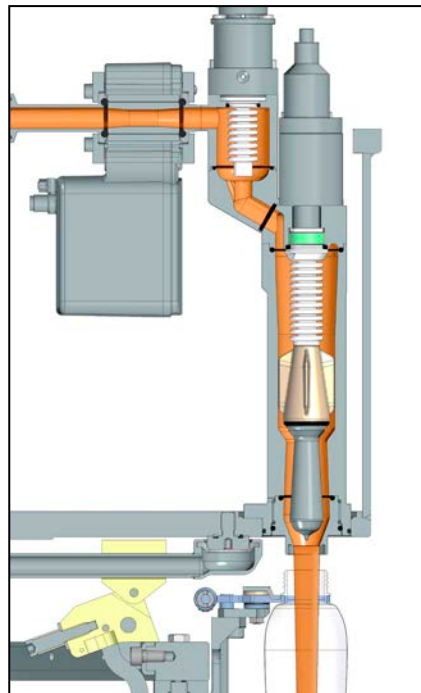

FX P EVO filling valve for still products with and without pulps and fibres with maximum dimensions of 3 mm diameter x 20 mm length

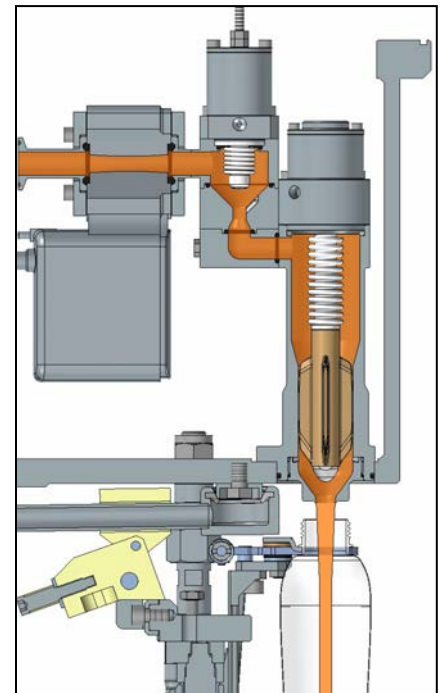

FX C filling valve for still products with and without pulps, fibres, pieces with dimensions up to 6x6x6 mm

GEA Process Engineering

GEA Procomac

Via Fedolfi, 29 - 43038 Sala Baganza (PR) Italy
 Tel: +39 0521 839411, Fax: +39 0521 833879
 sales.procomac.it@gea.com, www.gea.com